

## Vertical Balers

### B-series



## Baler B20

### Flexible baler for various types of industries

Compact different types of recyclable materials including cardboard, paper, and soft plastic.

### Bales are perfect pallet size

Bale dimension is optimized for transport and finished bales fit on a standard EUR pallet.

### Highlights

- Easy tying of the bales
- High throughput
- Short press cycle
- Front-placed strap rolls for close-to-wall installation
- High compression ratio
- Bales fit on a standard EUR pallet
- Powder Coating provides durable finish in many colors

## Optional Extras



Gain remote control of your baler with our intelligent fleet monitoring system, BRA-IN.



You may choose other RAL colours for your balers.



Reduce baler cycle time with regenerative circuit

# Product details

## Baler B20



Whisper

30 dB



Refrigerator

50 dB



**B20**

**62-64 dB**



Other balers

75 dB

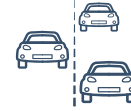

Cars on highway

100 dB



Turbojet engine

160 dB

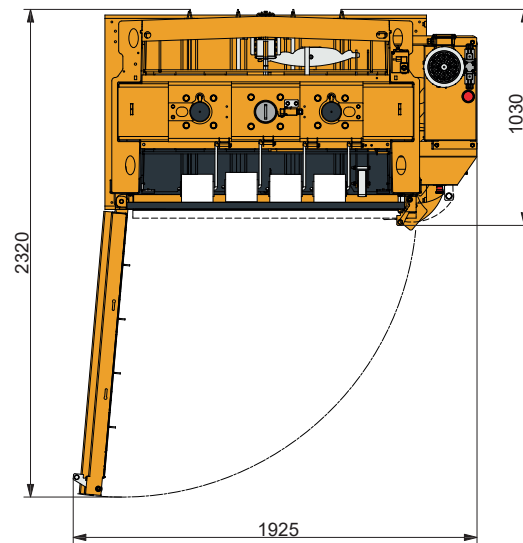
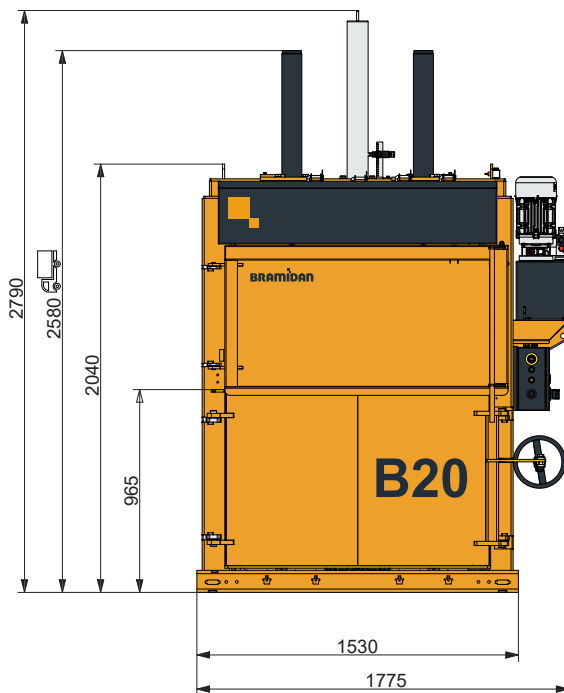

### Technical specifications

Bale size WxDxH (mm)	1200 x 800 x 800
Feed opening WxH (mm)	1200 x 480
Power supply	3x400V 50Hz 16A
Motor (kW)	4.0
Cycle time avg. (sec)	36 / 21
Dimensions WxDxH (mm)	1775 x 1030 x 2790
Weight (kg)	1250
Stroke (mm)	750
Number of ties	4
Type of tying	Twine
Full bale light	Yes
Bale eject	Automatic



### Bale weight

Cardboard (kg) 200-250  
 Plastic foil (kg) 250-300



### Press force

20 t



### Noise level

62-64 dB



### Waste types

Cardboard, plastic foil, paper.

**BRAMIDAN**  
 bramidan.com

Bramidan A/S  
 Industrivej 69  
 6740 Bramming  
 Denmark  
 Tel. +45 7517 3266  
 bramidan@bramidan.dk