

Vertical Balers

B-series



Baler B20

Versatile machine for various industries

This machine allows you to recycle a variety of materials in a number of different industries.

Optimal bale size

Finished bales are the optimal size. They fit on a standard US pallet and can be transported easily.

Highlights

- Low noise level (<62 dB)
- Quickly tie off bales
- Impressive throughput
- Short press cycle
- Install against wall with front placed strapping
- Large compression ratio
- Powder Coating provides durable finish in many colors.

Optional Extras



Gain remote control of your baler with our intelligent fleet monitoring system, BRA-IN.



You may choose other RAL colours for your balers.



Reduce baler cycle time with regenerative circuit.

Product details

Baler B20



Whisper

30 dB



Refrigerator

50 dB



B20

62-64



Other balers

75 dB

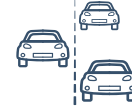

Cars on highway

100 dB



Turbojet engine

160 dB

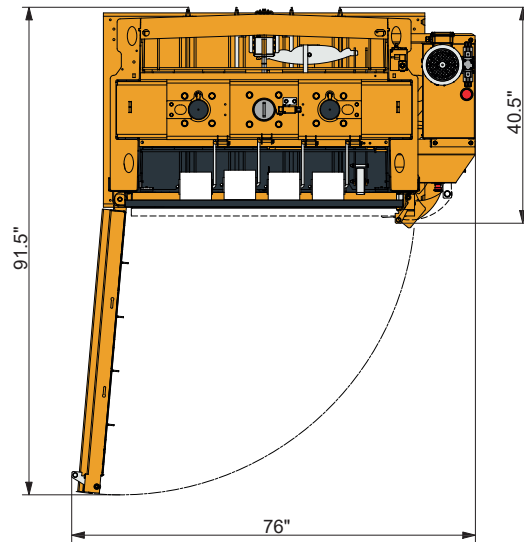
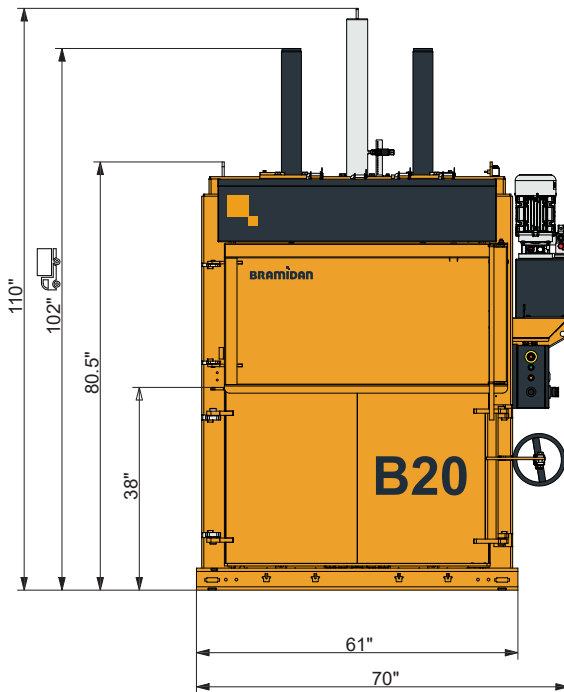

Technical specifications

Bale size WxDxH (inch)	48 x 30 x 30
Feed opening WxH (inch)	48 x 22
Power supply	208/230/480V 3-phase 60Hz
Motor (HP)	5.5
Cycle time avg. (sec)	37
Dimensions WxDxH (inch)	70 x 41 x 110 / 81
Weight (lbs)	2,760
Stroke (inch)	30
Number of ties	4
Type of tying	Twine
Full bale light	Yes
Bale eject	Automatic



Bale weight	
Cardboard (lbs)	450-550
Plastic foil (lbs)	550-650



Press force	44,100 lbs
--------------------	------------



Noise level	62-64
--------------------	-------



Waste types	Cardboard, plastic foil, paper.
--------------------	---------------------------------