

# Vertical Balers

## B-series



## Baler B5 Wide

### For large and bulky materials

An extra wide baler designed to handle large and bulky materials. The largest boxes can be thrown right in without being broken down.

### Easy installation and wide application

This baler operates on a single phase power supply, which makes it easy to install in a wide variety of environments.

### Highlights

- High capacity – large output
- Wide filling opening (1 metre)
- Efficient retainers hold compressed material down
- The bale is tipped out automatically
- Front-placed strap rolls for easy strap change
- Operates on single phase power supply
- Complies with EU Safety Standard EN16500
- Powder Coating provides durable finish in many colors.

## Optional Extras



With our monitoring system BRA-IN you can control and optimize your baler fleet.



Balers are available in other RAL colours which you may choose.



Block access to baler controls with auto lock.

# Product details

## Baler B5 Wide



Whisper

30 dB



Refrigerator

50 dB



**B5 Wide**

65-68 dB

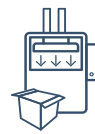

Other balers

75 dB

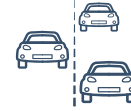

Cars on highway

100 dB



Turbojet engine

160 dB

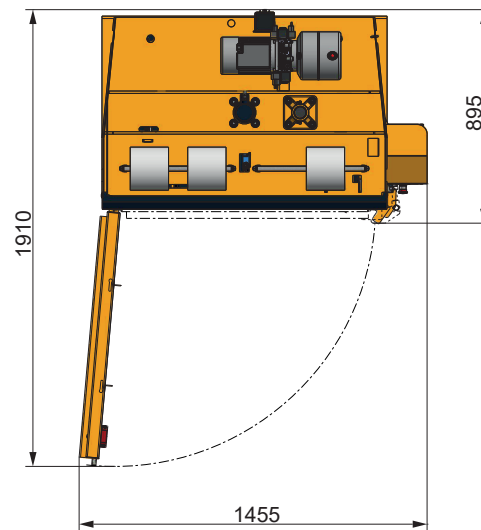
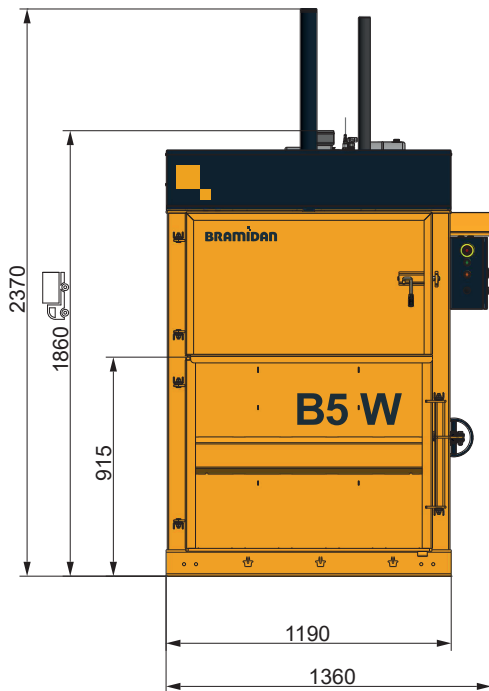

### Technical specifications

Bale size WxDxH (mm)	1000 x 700 x 800
Feed opening WxH (mm)	1000 x 500
Power supply	1x230V 50Hz 10A
Motor (kW)	1.1
Screen 40 mm (m <sup>3</sup> /h)	33
Dimensions WxDxH (mm)	1360 x 895 x 2370
Weight (kg)	600
Stroke (mm)	750
Number of ties	3
Type of tying	Twine
Full bale light	Yes
Bale eject	Automatic



#### Bale weight

Cardboard (kg) 80-110  
Plastic foil (kg) 90-130



#### Press force

5 t



#### Noise level

65-68 dB



#### Waste types

Cardboard, plastic foil, paper.

**BRAMIDAN**  
bramidan.ie

Bramidan Ireland  
Unit 5 Feltrim Business Park  
Drynam Road  
Swords, Co Dublin K67 VK51  
Tel. 1 890 0660  
sales@acmesystems.ie / sales@bramidan.ie