

Vertical Balers

X-series



Baler X50 HD Galvanized FD

Withstands severe demands from environment

When demands on the machine are severe enough to demand a special surface treatment, the galvanized finish is suitable for all applications without hygienic requirements for stainless steel.

Highlights

- ASTM A123/A123M galvanized
- Suitable for all recyclable waste types
- Handles aluminum cans, PET bottles, and plastic jugs
- Available with drain for residual liquids

Optional Extras



A draining system leads liquids out of your baler during compaction of wet waste.



Prevent unauthorized people from operating your baler with a digital auto lock.



Gain remote control of your baler with our intelligent fleet monitoring system, BRA-IN.

Product details

Baler X50 HD Galvanized FD



Whisper

30 dB



Refrigerator

50 dB



X50 HD Galvanized
FD

62-64
dB



Other balers

75 dB

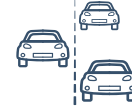

Cars on highway

100 dB



Turbojet engine

160 dB

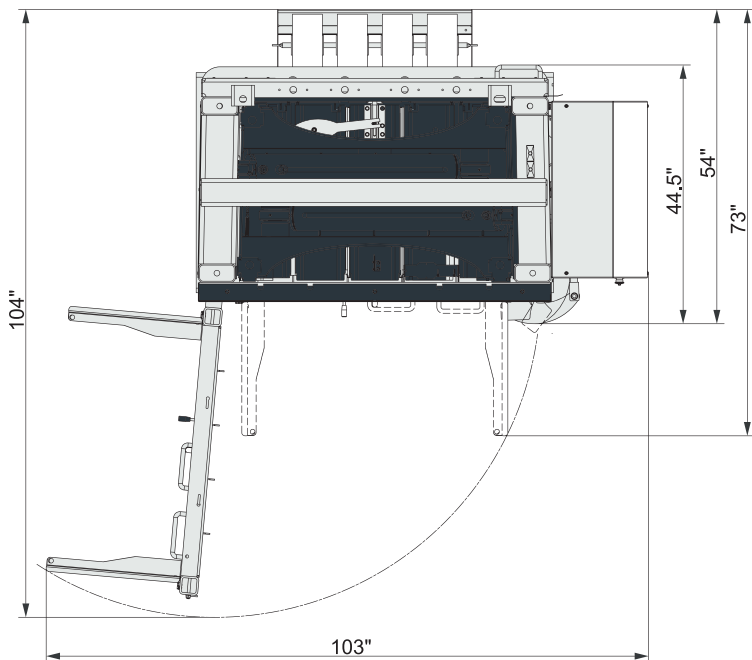
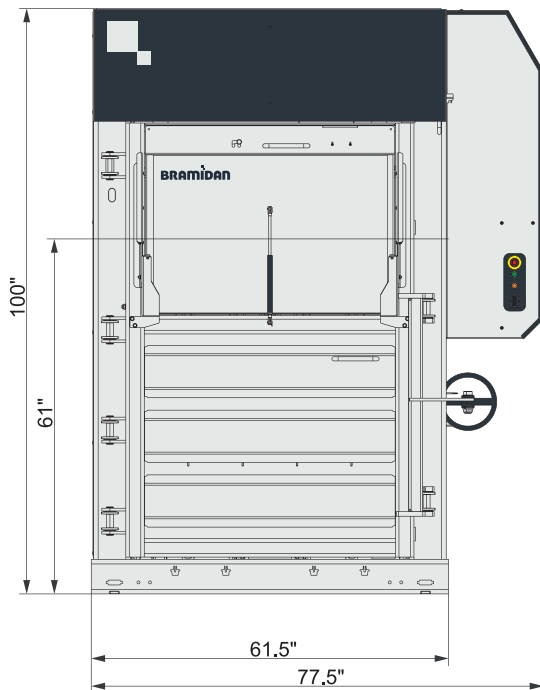

Technical specifications

Bale size WxDxH (inch)	48 x 30 x 48
Feed opening WxH (inch)	38 x 20
Power supply	208/230/480V 3-phase 60Hz
Motor (HP)	7.5
Cycle time avg. (sec)	18
Dimensions WxDxH (inch)	78 x 73 x 100
Weight (lbs)	5,900
Stroke (inch)	48
Number of ties	4
Type of tying	Twine / Steel wire
Full bale light	Yes
Bale eject	Automatic



Bale weight
Cardboard (lbs) 750-1,000
Plastic foil (lbs) 850-1,200



Press force 110,000 lbs



Noise level 62-64 dB



Waste types
Cardboard, plastic foil, paper, PET bottles, alu cans, tin cans, hard plastic, liquid, EPS.