

Vertical Balers

X-series



Baler X50 HD FD

Efficient compaction

The X50 HD baler compacts heavy-duty materials quickly and efficiently. Easily bale aluminum and tin cans, hard plastic (PET), soft expandable plastic, and paper.

Produce heavy bales

High-capacity machine that produces heavy bales of up to 1,200 lbs. It has a long lifetime due to the unique design and reliable hydraulics.

Highlights

- Most material types are compacted easily
- Impressive compression ratio
- Very little expansion of material between press cycles
- Tie off finished bales with either steel wire or plastic strapping
- Fast press cycle
- Electrical control panel safe and easy to access
- All moving parts located inside machine
- Powder Coating provides durable finish in many colors

Optional Extras



Balers are available in other RAL colours which you may choose.



A galvanized surface makes your baler environmentally resistant.



With our monitoring system BRA-IN you can control and optimize your baler fleet.

Product details

Baler X50 HD FD



Whisper

30 dB



Refrigerator

50 dB



X50 HD FD

62-64 dB



Other balers

75 dB

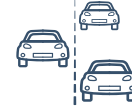

Cars on highway

100 dB



Turbojet engine

160 dB

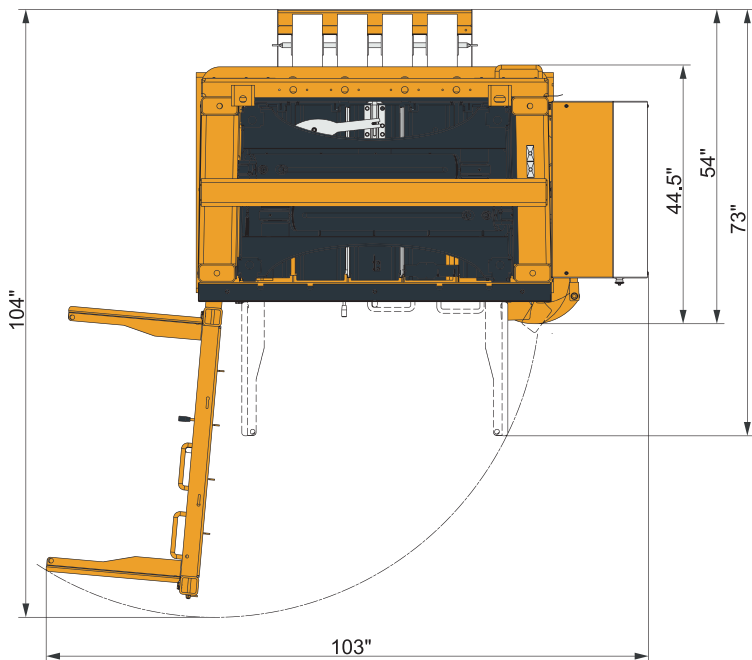
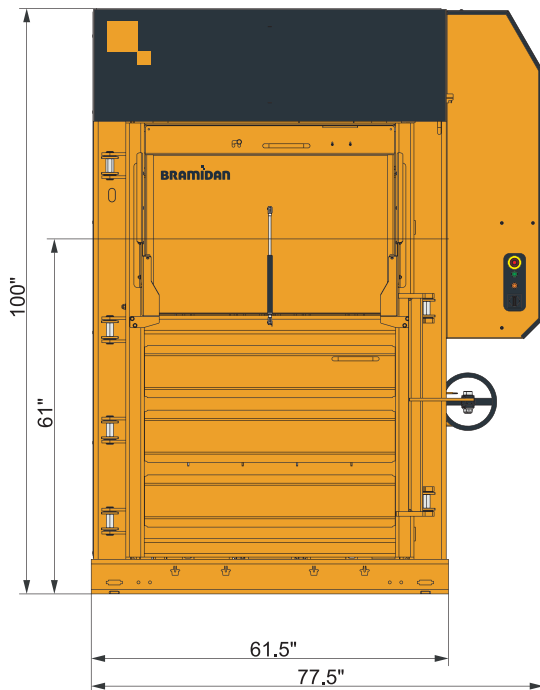

Technical specifications

Bale size WxDxH (inch)	48 x 30 x 48
Feed opening WxH (inch)	38 x 20
Power supply	3x400V 50Hz 16A
Motor (HP)	7.5
Cycle time avg. (sec)	18
Dimensions WxDxH (inch)	78 x 69 x 102
Weight (lbs)	5,900
Stroke (inch)	48
Number of ties	4
Type of tying	Twine / Steel wire
Full bale light	Yes
Bale eject	Automatic



Bale weight	
Cardboard (lbs)	750-1,000
Plastic foil (lbs)	850-1,200



Press force	110,000 lbs
--------------------	-------------



Noise level	62-64 dB
--------------------	----------



Waste types	Cardboard, plastic foil, paper, PET bottles, alu cans, tin cans, hard plastic, textile, EPS.
--------------------	--